

TIA/EIA INTERIM STANDARD

Interoperability Specification (IOS) for cdma2000 Access Network Interfaces

Release B

Part 2: Transport

TIA/EIA/IS-2001.2-B

MAY 2002

TELECOMMUNICATIONS INDUSTRY ASSOCIATION



The Telecommunications Industry Association
represents the communications sector of



NOTICE

TIA/EIA Engineering Standards and Publications are designed to serve the public interest through eliminating misunderstandings between manufacturers and purchasers, facilitating interchangeability and improvement of products, and assisting the purchaser in selecting and obtaining with minimum delay the proper product for his particular need. Existence of such Standards and Publications shall not in any respect preclude any member or nonmember of TIA/EIA from manufacturing or selling products not conforming to such Standards and Publications, nor shall the existence of such Standards and Publications preclude their voluntary use by those other than TIA/EIA members, whether the standard is to be used either domestically or internationally.

Standards and Publications are adopted by TIA/EIA in accordance with the American National Standards Institute (ANSI) patent policy. By such action, TIA/EIA does not assume any liability to any patent owner, nor does it assume any obligation whatever to parties adopting the Standard or Publication.

TIA/EIA INTERIM STANDARDS

TIA/EIA Interim Standards contain information deemed to be of technical value to the industry, and are published at the request of the originating Committee without necessarily following the rigorous public review and resolution of comments which is a procedural part of the development of a TIA/EIA Standard.

TIA/EIA Interim Standards should be reviewed on an annual basis by the formulating Committee and a decision made on whether to proceed to develop a TIA/EIA Standard on this subject. TIA/EIA Interim Standards must be cancelled by the Committee and removed from the TIA/EIA Standards Catalog before the end of their third year of existence.

Publication of this TIA/EIA Interim Standard for trial use and comment has been approved by the Telecommunications Industry Association. Distribution of this TIA/EIA Interim Standard for comment shall not continue beyond 36 months from the date of publication. It is expected that following this 36 month period, this TIA/EIA Interim Standard, revised as necessary, will be submitted to the American National Standards Institute for approval as an American National Standard. Suggestions for revision should be directed to: Standards & Technology Department, Telecommunications Industry Association, 2500 Wilson Boulevard, Arlington, VA 22201.

(From Project No. 4545.2-RV2, formulated under the cognizance of the TIA TR-45.4 Subcommittee on Radio to Switching Technology.)

Published by

©TELECOMMUNICATIONS INDUSTRY ASSOCIATION 2002
Standards & Technology Department
2500 Wilson Boulevard
Arlington, VA 22201

**PRICE: Please refer to current Catalog of
EIA ELECTRONIC INDUSTRIES ALLIANCE STANDARDS and ENGINEERING PUBLICATIONS or
call Global Engineering Documents, USA and Canada
(1-800-854-7179) International (303-397-7956)**

All rights reserved
Printed in U.S.A.

PLEASE!
DON'T VIOLATE
THE
LAW!

This document is copyrighted by the TIA and may not be reproduced without permission.

Organizations may obtain permission to reproduce a limited number of copies through entering into a license agreement. For information, contact:

Global Engineering Documents
15 Inverness Way East
Englewood, CO 80112-5704 or call
U.S.A. and Canada 1-800-854-7179, International (303) 397-7956

NOTICE OF DISCLAIMER AND LIMITATION OF LIABILITY

The document to which this Notice is affixed has been prepared by one or more Engineering Committees of the Telecommunications Industry Association (“TIA”). TIA is not the author of the document contents, but publishes and claims copyright to the document pursuant to licenses and permission granted by the authors of the contents.

TIA Engineering Committees are expected to conduct their affairs in accordance with the TIA Engineering Manual (“Manual”), the current and predecessor versions of which are available at http://www.tiaonline.org/standards/sfg/engineering_manual.cfm. TIA’s function is to administer the process, but not the content, of document preparation in accordance with the Manual and, when appropriate, the policies and procedures of the American National Standards Institute (“ANSI”).

THE USE OR PRACTICE OF CONTENTS OF THIS DOCUMENT MAY INVOLVE THE USE OF INTELLECTUAL PROPERTY RIGHTS (“IPR”), INCLUDING PENDING OR ISSUED PATENTS, OR COPYRIGHTS, OWNED BY ONE OR MORE PARTIES. TIA MAKES NO SEARCH OR INVESTIGATION FOR IPR. WHEN IPR CONSISTING OF PATENTS AND PUBLISHED PATENT APPLICATIONS ARE CLAIMED AND CALLED TO TIA’S ATTENTION, A STATEMENT FROM THE HOLDER THEREOF IS REQUESTED, ALL IN ACCORDANCE WITH THE MANUAL. TIA TAKES NO POSITION WITH REFERENCE TO, AND DISCLAIMS ANY OBLIGATION TO INVESTIGATE OR INQUIRE INTO, THE SCOPE OR VALIDITY OF ANY CLAIMS OF IPR.

ALL WARRANTIES, EXPRESS OR IMPLIED, ARE DISCLAIMED, INCLUDING WITHOUT LIMITATION, ANY AND ALL WARRANTIES CONCERNING THE ACCURACY OF THE CONTENTS, ITS FITNESS OR APPROPRIATENESS FOR A PARTICULAR PURPOSE OR USE, ITS MERCHANTABILITY AND ITS NON-INFRINGEMENT OF ANY THIRD PARTY’S INTELLECTUAL PROPERTY RIGHTS. TIA EXPRESSLY DISCLAIMS ANY AND ALL RESPONSIBILITIES FOR THE ACCURACY OF THE CONTENTS AND MAKES NO REPRESENTATIONS OR WARRANTIES REGARDING THE CONTENT’S COMPLIANCE WITH ANY APPLICABLE STATUTE, RULE OR REGULATION.

TIA SHALL NOT BE LIABLE FOR ANY AND ALL DAMAGES, DIRECT OR INDIRECT, ARISING FROM OR RELATING TO ANY USE OF THE CONTENTS CONTAINED HEREIN, INCLUDING WITHOUT LIMITATION ANY AND ALL INDIRECT, SPECIAL, INCIDENTAL OR CONSEQUENTIAL DAMAGES (INCLUDING DAMAGES FOR LOSS OF BUSINESS, LOSS OF PROFITS, LITIGATION, OR THE LIKE), WHETHER BASED UPON BREACH OF CONTRACT, BREACH OF WARRANTY, TORT (INCLUDING NEGLIGENCE), PRODUCT LIABILITY OR OTHERWISE, EVEN IF ADVISED OF THE POSSIBILITY OF SUCH DAMAGES. THE FOREGOING NEGATION OF DAMAGES IS A FUNDAMENTAL ELEMENT OF THE USE OF THE CONTENTS HEREOF, AND THESE CONTENTS WOULD NOT BE PUBLISHED BY TIA WITHOUT SUCH LIMITATIONS.

Table of Contents

1
2
3
4
5
6
7
8
9
10
11
12
13
14
15
16
17
18
19
20
21
22
23
24
25
26
27
28
29
30
31
32
33
34
35
36
37
38
39
40
41
42
43
44
45
46
47
48
49
50
51
52
53
54
55

1.0	Introduction.....	1
1.1	Overview.....	1
1.1.1	Purpose.....	1
1.1.2	Scope.....	1
1.2	References.....	1
1.2.1	TIA / EIA	1
1.2.2	3GPP2	2
1.2.3	Standards Committee T1.....	2
1.2.4	International Telecommunications Union - Telecommunications Sector (ITU-T)	2
1.2.5	Other	2
1.3	Terminology.....	3
1.3.1	Acronyms	3
1.3.2	Definitions.....	5
2.0	Network and Transport Protocols	7
2.1	Protocol Reference Model – A1 Interface.....	7
2.1.1	MSC-BS Interface Channel Types	7
2.1.2	Transport Protocols	7
2.1.3	Layer 1	7
2.1.4	Layer 2 - Transport Protocols.....	7
2.1.4.1	SS7 Signaling Transport	7
2.1.5	Layer 3 - A1 Interface: Base Station Application Part.....	7
2.2	Signaling Connection Transport Protocol Options	8
2.3	User Traffic Connection Transport Protocol Options	10
3.0	Physical Layer Specification (Layer 1).....	13
4.0	Use of ANSI SS7 Transport (Layer 2).....	15
4.1	Field of Application	15
4.2	Message Transfer Part.....	16
4.2.1	General	16
4.2.2	Level 1 (T1.111.2).....	16
4.2.3	Level 2 (T1.111.3).....	16
4.2.4	Level 3 (T1.111.4).....	17
4.2.5	Testing and Maintenance (T1.111.7)	19
4.2.6	Interface Functions.....	19
4.2.7	Overload Control (Message Throughput Congestion)	19
4.3	SCCP Transport Layer Specification (SCCP Functions).....	20
4.3.1	Overview.....	20
4.3.2	Primitives (T1.112.1)	20
4.3.3	SCCP Messages (T1.112.2)	21
4.3.4	SCCP Formats and Codes (T1.112.3)	22
4.3.5	SCCP Procedures (T1.112.4)	23
4.4	Use of the SCCP	24
4.4.1	The Direct Transfer Application Part.....	25
4.4.2	The BS Management Application Part.....	25
4.4.3	Connection Establishment.....	25
4.4.3.1	Establishment Procedure - Case 1	25
4.4.3.2	Establishment Procedure - Case 2	27
4.4.4	Connection Release	28
4.4.5	Abnormal SCCP Release	28
4.4.5.1	SCCP Release by BS: Loss of SCCP Connection Information.....	29
4.4.5.2	SCCP Release by MSC: Loss of SCCP Connection Information	29
4.4.6	SCCP Reference Generation Philosophy	30
4.4.7	SCCP Transfer of DTAP and BSMAP Messages	31
5.0	Use of ATM (Layer 2)	37

1 5.1 ATM Layer 37
2 5.2 ATM Adaptation Layer..... 37
3 5.3 Use of ATM AAL5 for Transmission of IP Datagrams 38
4 6.0 TCP Transport Protocol Usage 39
5 6.1 General Use of TCP 39
6 6.1.1 Message Delimiting in TCP 39
7 6.1.2 TCP Connection Establishment 40
8 6.1.3 TCP Connection Release..... 40
9 6.1.4 TCP Port Usage..... 40
10 6.2 Use of TCP for the A3 and A7 Interfaces 40
11 6.3 Use of TCP for the A9 Interface 41
12 7.0 IP Network Protocol Usage..... 43
13 8.0 UDP Transport Protocol Usage..... 45
14 8.1 UDP Transport Protocol Usage for the A11 Interface 45
15 8.2 UDP Transport Protocol Usage for the A9 Interface 45
16 9.0 Mobile IP Protocol Usage 47
17 10.0 GRE Protocol Usage 49
18
19

List of Figures

1
2
3
4
5
6
7
8
9
10
11
12
13
14
15
16
17
18
19
20
21
22
23
24
25
26

Figure 2.1.5-1 A1 Interface Signaling Protocol Reference Model..... 8

Figure 2.2-1 A1 Signaling Protocol Stack 9

Figure 2.2-2 A3 and A7 Signaling Protocol Stack..... 9

Figure 2.2-3 A9 Signaling Protocol Stack 10

Figure 2.2-4 A11 Signaling Protocol Stack 10

Figure 2.3-1 A2 User Traffic Protocol Stacks 10

Figure 2.3-2 A5 User Traffic Protocol Stacks 11

Figure 2.3-3 A3 User Traffic Protocol Stack..... 11

Figure 2.3-4 A8 User Traffic Protocol Stack..... 11

Figure 2.3-5 A10 User Traffic Protocol Stack..... 12

Figure 4.4.3-1 SCCP Connection Establishment 26

Figure 4.4.3-2 SCCP Connection Establishment Refusal..... 26

Figure 4.4.3.2-1 SCCP Connection Establishment During Handoff..... 27

Figure 4.4.3.2-2 SCCP Connection Refusal During Handoff..... 28

Figure 4.4.5.1-1 BS Generated SCCP Release: BS Has Lost Access to SCCP
Connection Information 29

Figure 4.4.5.2-1 MSC Generated SCCP Release: MSC Has Lost Access to SCCP
Connection Information 30

Figure 4.4.6-1 SLR/DLR Usage 31

Figure 6.1.1-1 Delimiting Messages in an IOS Application TCP Byte Stream 39

Figure 10-1 GRE Encapsulated User Traffic 49

Figure 10-2 GRE Header 49

List of Tables

1
2
3
4
5
6

Table 4.4.7-1 Use of the User Data Field in SCCP Frames	31
Table 4.4.7-2 Use of SCCP for BSMAP and DTAP Messages	32

Foreword

(This foreword is not part of this standard.)

This document was produced by Working Groups TR45.4 of the Telecommunications Industry Association and TSG-A of the Third Generation Partnership Project 2. This document was developed in accordance with TIA/EIA and 3GPP2 procedural guidelines, and represents the consensus position of the Working Groups.

The Working Groups acknowledge the contributions made by the following individuals in the development of this standard:

Name	Representing	Position
Dale Baldwin	Sprint PCS	TIA TR45.4 Chair
George Turnipseed	Sprint PCS	3GPP2 TSG-A Chair
Roger Edwards	3GPP2 Secretariat	Professional Editor
Srini Rao	Winphoria	Part 1 (Overview) Technical Editor
Scott Marin	Motorola	Part 2 (Transport) Technical Editor
Bill Semper	Samsung	Part 3 (Features) Technical Editor and Chair for Comment Resolution
Yasaman Abtahi and Mini Vasudevan	Nortel Networks	Part 4 (A1/A2/A5) Technical Editors
Janice Wunsch	Lucent Technologies	Part 5 (A3/A7) Technical Editor
Shahab Sayeedi	Motorola	Part 6 (A8/A9) Technical Editor
Roger Gustavsson and Erik Colban	Ericsson	Part 7 (A10/A11) Technical Editors

Suggestions for improvement of this standard are welcome. They should be sent to:
 Telecommunications Industry Association
 Engineering Department
 Suite 300
 250 Wilson Boulevard
 Arlington, VA 22201 USA

1
2
3
4
5
6
7
8

(This page intentionally left blank.)

1.0 Introduction

1.1 Overview

This document contains the protocol definitions and transport requirements for the interfaces defined in this specification.

1.1.1 Purpose

The purpose of this document is to describe the transport protocols and protocol stacks used on the interfaces, which make up the logical network model, and to indicate any unique aspects of these protocols that are relevant to the IOS.

1.1.2 Scope

This document contains generic and specific requirements for the IOS interfaces. The document contains the generic protocol descriptions that are used through all of the IOS interfaces. In addition, protocol stack and transport network requirements for each IOS interface are contained in this document. Details of the IOS application and signaling layer messages are contained in the respective interface documents [14], [15], [16], and [17].

1.2 References

1.2.1 TIA / EIA

For ease of cross referencing, the Telecommunications Industry Association (TIA) / Electronics Industry Association (EIA) references provided in this section are aligned with the 3GPP2 references, provided in section 1.2.2.

- [1-7] Reserved.
- [8] TIA/EIA/IS-835-A, *cdma2000 Wireless IP Network Standard*, May 2001.
- [9-12] Reserved.
- [13] TIA/EIA-2001.3-B, *Interoperability Specification (IOS) for CDMA 2000 Access Network Interfaces – Part 3 Features*, May 2002.
- [14] TIA/EIA-2001.4-B, *Interoperability Specification (IOS) for CDMA 2000 Access Network Interfaces – Part 4 (A1, A2, and A5 Interfaces)*, May 2002.
- [15] TIA/EIA-2001.5-B, *Interoperability Specification (IOS) for CDMA 2000 Access Network Interfaces – Part 5 (A3 and A7 Interfaces)*, May 2002.
- [16] TIA/EIA-2001.6-B, *Interoperability Specification (IOS) for CDMA 2000 Access Network Interfaces – Part 6 (A8 and A9 Interfaces)*, May 2002.
- [17] TIA/EIA-2001.7-B, *Interoperability Specification (IOS) for CDMA 2000 Access Network Interfaces – Part 7 (A10 and A11 Interfaces)*, May 2002.

1.2.2 3GPP2

The 3GPP2 references are aligned with the TIA/EIA references of Section 1.2.1 and are provided here for information and cross reference purposes.

- [1-7] Reserved.
- [8] 3GPP2 P.S0001-A, “Wireless IP Network Standard”, July, 2000.
- [9-12] Reserved.
- [13] 3GPP2 A.S0013-0, *Interoperability Specification (IOS) for cdma2000 Access Network Interfaces – Part 3 Features*, May 2002.
- [14] 3GPP2 A.S0014-0, *Interoperability Specification (IOS) for cdma2000 Access Network Interfaces – Part 4 (A1, A2, and A5 Interfaces)*, May 2002.
- [15] 3GPP2 A.S0015-0, *Interoperability Specification (IOS) for cdma2000 Access Network Interfaces – Part 5 (A3 and A7 Interfaces)*, May 2002.
- [16] A.S0016-0, *Interoperability Specification (IOS) for CDMA 2000 Access Network Interfaces – Part 6 (A8 and A9 Interfaces)*, May 2002.
- [17] A.S0017-0, *Interoperability Specification (IOS) for CDMA 2000 Access Network Interfaces – Part 7 (A10 and A11 Interfaces)*, May 2002.

1.2.3 Standards Committee T1

- [18] ANSI T1.101-1987, *Synchronization Interface Standards for Digital Networks*, 1987.
- [19] ANSI T1.111-1992, *Signaling System No. 7 (SS7) - Message Transfer Part (MTP)*, June, 1992.
- [20] ANSI T1.112-1992, *Signaling System No. 7 (SS7) - Signaling Connection Control Part (SCCP)*, October, 1992.
- [21] ANSI T1.627 - 1993, *B-ISDN - ATM Layer Functionality and Specification*, 1993.

1.2.4 International Telecommunications Union - Telecommunications Sector (ITU-T)

- [22] ITU-T Recommendation I.366.1, *Segmentation and Reassembly Service Specific Convergence Sublayer for the AAL type 2*, June, 1998.
- [23] ITU-T Recommendation Q.2931, *Broadband-Integrated Services Digital Network (B-ISDN) Digital Subscriber Signalling No. 2 (DSS2) User-Network Interface Layer 3 Specification for Basic Call/Connection Control*, 1995.

1.2.5 Other

- [24] Internet Engineering Task Force, *RFC 768 – User Datagram Protocol (UDP)*, 1980.
- [25] Internet Engineering Task Force, *RFC 791 – Internet Protocol (IP)*, 1981.
- [26] Internet Engineering Task Force, *RFC 793 – Transmission Control Protocol (TCP)*, 1981.
- [27] Internet Engineering Task Force, *RFC 1483 – Multiprotocol Encapsulation over ATM Adaptation Layer 5*, 1993.
- [28] Internet Engineering Task Force, *RFC 2002 – IP Mobility Support Specification*, 1996.
- [29] Internet Engineering Task Force, *RFC 2225 – Classical IP and ARP over ATM*, 1998.
- [30] Internet Engineering Task Force, *RFC 2784 - Generic Routing Encapsulation (GRE)*, 2000
- [31] Internet Engineering Task Force, *RFC 2890 - Key and Sequence Number Extensions to GRE*, 2000

1.3 Terminology

1.3.1 Acronyms

Acronym	Meaning
3GPP2	3rd Generation Partnership Project 2
AAL2	ATM Adaptation Layer type 2
AAL5	ATM Adaptation Layer type 5
ADDS	Application Data Delivery Service
Ack	Acknowledgement
AK	Acknowledge (Data)
ANSI	American National Standards Institute
Async	Asynchronous
ATM	Asynchronous Transfer Mode
B-ISDN	Broadband-Integrated Services Digital Network
BS	Base Station
BSAP	Base Station Application Part
BSMAP	Base Station Management Application Part
CC	Connection Confirm
CDG	CDMA Development Group
CDMA	Code Division Multiple Access
CIC	Circuit Identity Code
CL	Connectionless
CM	Connection Management
CO	Connection Oriented
CR	Connection Request
CREF	Connection Refused
DLR	Destination Local Reference
DPC	Destination Point Code
DS0	Digital Signal Level 0
DSS2	Digital Subscriber Signaling Number 2
DT1	Data Transfer 1
DT2	Data Form 2
DTAP	Direct Transfer Application Part
EA	Expedited Acknowledgment
ED	Expedited Data
E1	E1-type Digital Carrier
EIA	Electronics Industry Association

Acronym	Meaning
ERR	Error (Protocol Data Unit)
ESN	Electronic Serial Number
GRE	Generic Routing Encapsulation
GSM	Global System for Mobile Communications
IMSI	International Mobile Subscriber Identity
IOS	Interoperability Specification
IP	Internet Protocol
IS	Interim Standard
ISLP	Inter-System Link Protocol
IT	Inactivity Test
ITU-T	International Telecommunications Union – Telecommunications Standardization Sector
LLC	Logical Link Control
LSB	Least Significant Bit
Mbps	Million Bits per Second
MS	Mobile Station
MSB	Most Significant Bit
MSC	Mobile Switching Center
Msg	Message
MTP	Message Transfer Part
OC3	Optical Carrier Level 3
PACA	Priority Access and Channel Assignment
PCF	Packet Control Function
PCM	Pulse Code Modulation
PDSN	Packet Data Serving Node
PLMN	Public Land Mobile Network
PPP	Point to Point Protocol
PVC	Permanent Virtual Circuit
QoS	Quality of Service
RFC	Request For Comment
RLC	Release Complete (SCCP)
RLSD	Release (SCCP)
RSC	Reset Confirm
RSR	Reset Request
SCCP	Signaling Connection Control Part
SDU	Service Data Unit (ATM)
SID	Session Identifier
SLR	Source Local Reference
SLS	Signaling Link Selection
SLTM	Signaling Link Test Message

Acronym	Meaning
SNAP	Sub Network Attachment Point
SOG	Subsystem Out-of-service Grant
SOR	Subsystem Out-of-service
SP	Signaling Point
SS7	Signaling System Number 7
SSADT	Service Specific Assured Data Transfer
SSN	Subsystem Number
SSSAR	Service Specific Segmentation and Reassembly
SSTED	Service Specific Transmission Error Detection
STP	Signaling Transfer Point
SVC	Switched Virtual Connection
T1	T1-type Digital Carrier
T3	T3-type Digital Carrier
TCP	Transmission Control Protocol
TFA	Transfer-Allowed Signal
TFP	Transfer-Prohibited Signal
TFR	Transfer-Restricted Signal
TIA	Telecommunications Industry Association
UDI	Unrestricted Digital Information
UDP	User Datagram Protocol
UDT	Unit Data (SCCP)
UDTS	Unit Data Service (SCCP)
UNI	User Network Interface
VC	Virtual Circuit
Ver	Version

1 **1.3.2** **Definitions**

2 Reserved

3

1
2
3
4
5
6
7

(This page intentionally left blank.)

2.0 Network and Transport Protocols

2.1 Protocol Reference Model – A1 Interface

2.1.1 MSC-BS Interface Channel Types

The MSC-BS interface consists of user traffic channels and signaling channels. In general, user traffic channels are independent of signaling channels. Different paths and different underlying transport technologies can be employed for each.

2.1.2 Transport Protocols

The MSC-BS interface referred to within this specification is designed to support a wide range of implementations.

2.1.3 Layer 1

The physical interface is based on the layer 1 interfaces.

2.1.4 Layer 2 - Transport Protocols

This standard specifies multiple protocols for the transport of signaling and user information.

2.1.4.1 SS7 Signaling Transport

When SS7 is used to provide signaling transport, the underlying transport mechanism defined to carry signaling information between the BS and the MSC is the Message Transfer Part (MTP), and the Signaling Connection Control Part (SCCP) of Signaling System No. 7 (SS7).

The MTP and SCCP are used to transport the application layer signaling protocol which is defined as the BS Application Part (BSAP).

2.1.5 Layer 3 - A1 Interface: Base Station Application Part

The Base Station Application Part (BSAP) is the application layer signaling protocol that provides messaging to accomplish the functions of the A1 Interface component of the MSC - BS Interface. BSAP is split into two sub-application parts; the BS Management Application Part (BSMAP), and the Direct Transfer Application Part (DTAP). Refer to Figure 2.1.5-1 “A1 Interface Signaling Protocol Reference Model” for an illustration of this structure.

The BS Management Application Part (BSMAP) supports all Radio Resource Management and Facility Management procedures between the MSC and the BS, or to a cell(s) within the BS. BSMAP messages are not passed to the MS, but are used only to

1 perform functions at the MSC or the BS. A BSMAP message (Complete Layer 3
 2 Information) is also used together with a DTAP message to establish a connection for a
 3 MS between the BS and the MSC, in response to the first layer 3 air interface message
 4 sent by the MS to the BS for each MS system request. The description of the layer 3
 5 protocol for the BSMAP information exchange is contained within this specification.

6 The Direct Transfer Application Part (DTAP) messages are used to transfer call
 7 processing and mobility management messages between the MSC and BS. DTAP
 8 messages carry information that is primarily used by the MS. The BS shall map the
 9 DTAP messages going to and coming from the MSC from/into the appropriate air
 10 interface signaling protocol.

11 Refer to [14] for a list of BSMAP and DTAP messages.

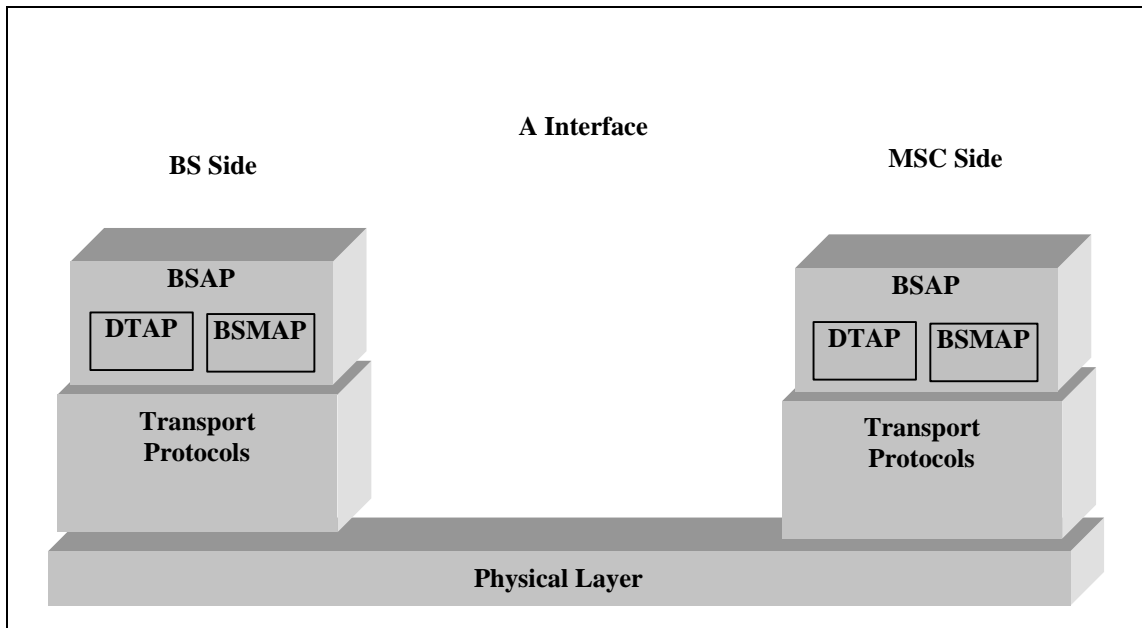

12
 13 **Figure 2.1.5-1 A1 Interface Signaling Protocol Reference Model**

14

15 **2.2 Signaling Connection Transport Protocol Options**

16 Signaling over the A1, A3, A7, A9 and A11 interfaces requires a reliable transport
 17 protocol and appropriate addressing and routing mechanisms to deliver messages from
 18 source to destination. The IOS application is independent of the underlying transport,
 19 which is left to the discretion of operators and manufacturers. The signaling protocol
 20 stack options available to operators and manufacturers for the A1, A3, A7, A9 and A11
 21 interfaces include:

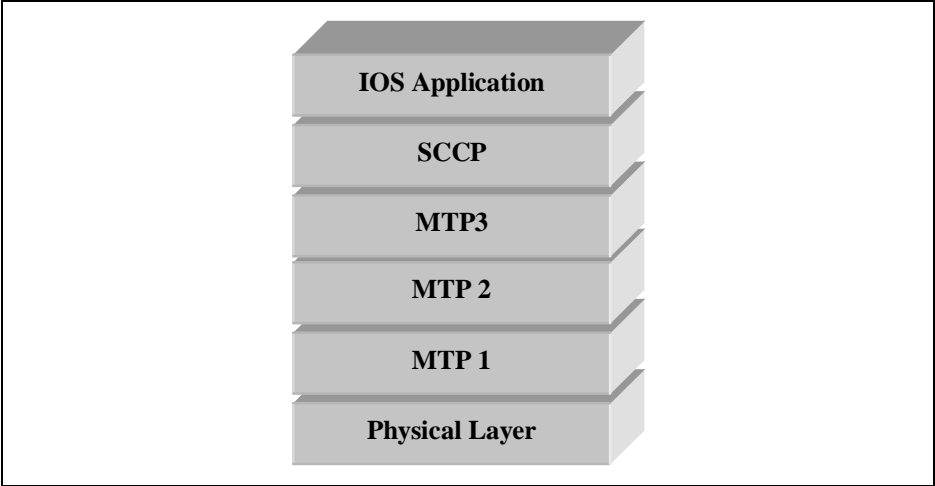

1

2

Figure 2.2-1 A1 Signaling Protocol Stack

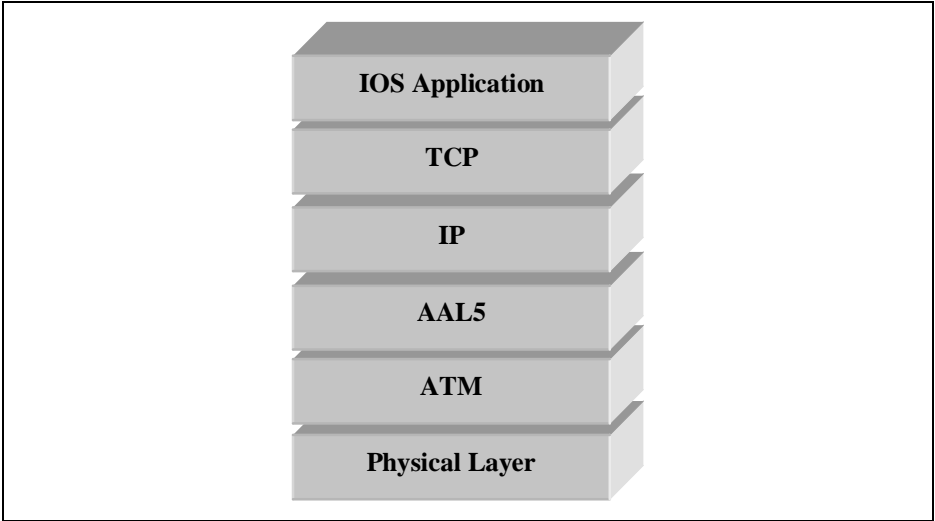

3

4

Figure 2.2-2 A3 and A7 Signaling Protocol Stack

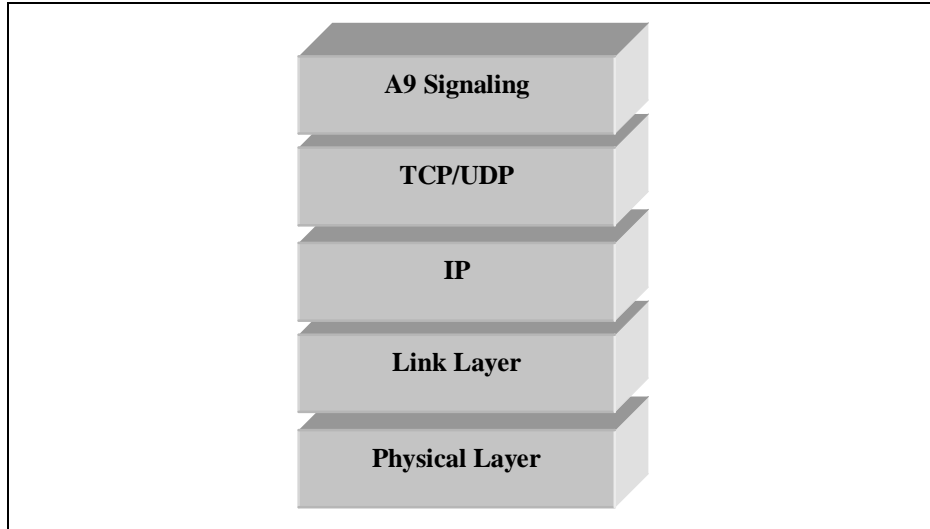

1

Figure 2.2-3 A9 Signaling Protocol Stack

2

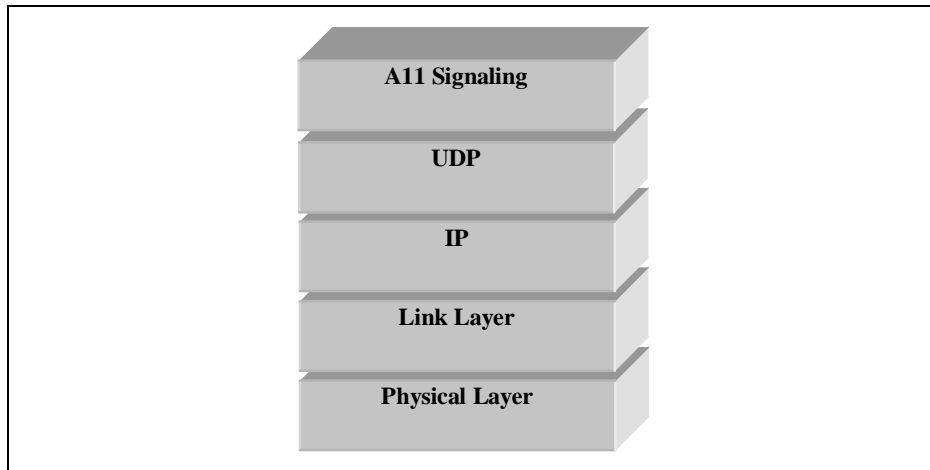

3

Figure 2.2-4 A11 Signaling Protocol Stack

4

2.3 User Traffic Connection Transport Protocol Options

5

The protocol stack options for transport of user traffic that are available to operators and manufacturers include:

6

7

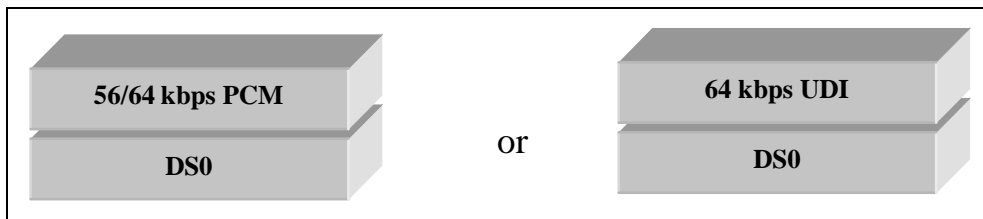

8

Figure 2.3-1 A2 User Traffic Protocol Stacks

9

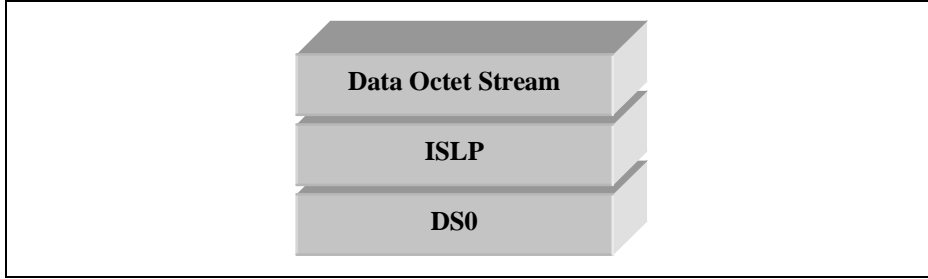

1

2

Figure 2.3-2 A5 User Traffic Protocol Stacks

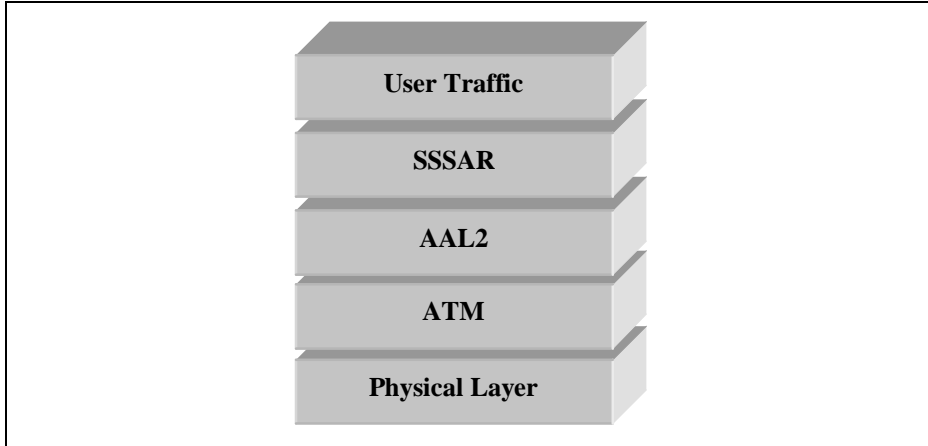

3

4

Figure 2.3-3 A3 User Traffic Protocol Stack

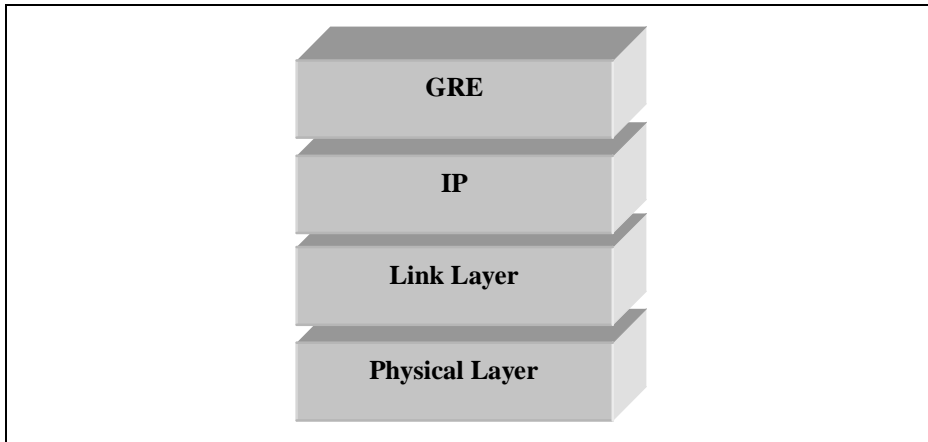

5

6

Figure 2.3-4 A8 User Traffic Protocol Stack

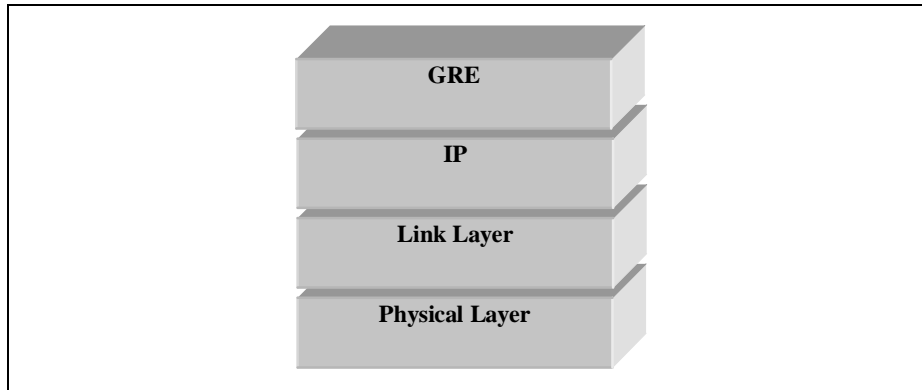

1

2

3

Figure 2.3-5 A10 User Traffic Protocol Stack

3.0 Physical Layer Specification (Layer 1)

The A1, A2, A3, A5 and A7 interfaces are based on the use of:

- T1 digital transmission system interfaces. Each 1.544 Mbps interface provides 24*56 kbps or 24*64 kbps channels which can be used for traffic or signaling as the operator requires. Common physical interface standards are found in [18] and related references. For a list of references, refer to section 1.2.
- E1 digital transmission interfaces consisting of 30*64 kbps user channels can also be used for traffic or signaling as the operator requires, and as applicable to the network.

As a BS/MSC agreed option, dedicated DS0 signaling link[s] may be used instead of the T1/E1 interface.

- T3 digital transmission interfaces supporting transmission rates of 43.232 Mbps.
- OC3 digital transmission interfaces supporting transmission rates of 155.52 Mbps.

The A8, A9, A10 and A11 interfaces are based on the use of the Internet Protocol (IP). IP can operate across various physical layer media. The specific layer 1 media and layer 2 link protocols to be used for these interfaces are not specified in this standard.

1
2
3
4
5
6

(This page intentionally left blank.)

4.0 Use of ANSI SS7 Transport (Layer 2)

This standard specifies multiple protocols for the transport of signaling and user information. Refer to section 2.

When SS7 is used to provide signaling transport, the underlying transport mechanism defined to carry signaling information between the BS and the MSC is the Message Transfer Part (MTP), and the Signaling Connection Control Part (SCCP) of Signaling System No. 7 (SS7).

The MTP and SCCP are used to transport the application layer signaling protocol which is defined as the BS Application Part (BSAP).

Information for this section was excerpted from [19] and [20]. Section 4.2 deals with the Message Transfer Part (MTP). Section 4.3 deals with the Signaling Connection Control Part (SCCP) and its use.

The MTP provides a mechanism giving reliable transfer of signaling messages. Section 4.2 deals with the subset of the MTP that can be used between a Base Station (BS) and a Mobile Switching Center (MSC), which is compatible with a full MTP.

The SCCP is used to provide a referencing mechanism to identify a particular transaction relating to, for instance, a particular call. Section 4.3 identifies the SCCP subset that shall be used between a BS and an MSC. The SCCP can also be used to enhance the message routing for operations and maintenance information.

4.1 Field of Application

This section is applicable to the signaling between BSs and MSCs in Public Land Mobile Networks (PLMNs). It provides a minimum set of MTP requirements that may be implemented at a BS or MSC, while maintaining compatibility with the implementation of a full specification of the MTP.

This section defines the interfaces at the 56 or 64 kbps boundary to the BS or MSC and applies primarily to digital access arrangements. The use of analog arrangements is not supported.

The reliability of signaling links is an administrative concern. It is recommended that in the case where more than one multiplex system is required and reliability reasons dictate the use of a multiple link sets, then each signaling link should be assigned in a different multiplex system.

Only the associated mode of signaling is applicable to the BS.

The ANSI recommendations concerning MTP shall be taken as being requirements unless covered by a statement in this section.

4.2 Message Transfer Part

4.2.1 General

The MTP functions as specified in [19] are applicable. However, the following exceptions and modifications to those recommendations may be applied for the MSC to BS signaling. Refer to section 4.2.2 through section 4.2.4.

4.2.2 Level 1 (T1.111.2)

T1.111.2 Figure 2

These figures are for information only. For the MSC-BS Interface, interface point C is appropriate.

T1.111.2 Section 1.4 Analog Signaling Link

The use of analog signaling links is not an available option.

T1.111.2 Section 2 General

A signaling rate of 56/64 kbps is assumed.

T1.111.2 Section 3 Error Characteristics and Availability

Error characteristics and availability are an operator concern. Excessive errors could lead to inefficient use of the signaling links.

T1.111.2 Section 5 Digital Signaling Link

The standard arrangement is to derive the signaling link from a T1/E1 digital path. However, dedicated DS0 signaling link[s] may be used as a BS/MSC agreed option.

T1.111.2 Section 6 Analog Signaling Data Link

Only digital signaling data links are supported.

4.2.3 Level 2 (T1.111.3)

T1.111.3 Section 1.4 Signal Unit Error Correction

Only the basic error correction protocol is required.

T1.111.3 Section 7 Signaling Link Initial Alignment Procedure

In the initial alignment procedure specified in Recommendation T1.111.3 [19], only the emergency proving period is applicable for the BS. Thus, in states 02 and 03 of the initial alignment procedure status indication "N" is not sent from the BS. The BS should be capable of recognizing status indication "N" if received in order for the alignment procedure to complete.

4.2.4 Level 3 (T1.111.4)

T1.111.4 Section 1.1.2 End Point of a Signaling Link

The BS is only implemented as the end point of a signaling link. There are no Signaling Transfer Point (STP) network management features in the BS.

T1.111.4 Section 2

Since STP functions are not required for discrimination and routing, MTP functions used between the MSC and the BS can be simplified. Since the implementation of this interface is intended only for point-to-point applications, the routing function within MTP is preset to select the point code appropriate to the parent MSC.

T1.111.4 Section 2.2 Routing Label

Load sharing is performed on the BS with more than one signaling link by means of the Signaling Link Selection (SLS) field.

T1.111.4 Section 2.3 Message Routing Function

Load sharing between link sets is not required since there can only be one link set between the BS and MSC.

T1.111.4 Section 2.3.5 Handling of Messages under Signaling Link Congestion

The procedures for handling message congestion priority levels as defined for U. S. Signaling Networks in T1.111.4 Section 2.3.5.2 [19] shall be followed. The message priorities given in Appendix B of T1.111.5 [19] for SCCP and MTP messages shall be used. The remaining message priorities for BSMAP and DTAP messages are provided in [14].

T1.111.4 Section 2.4 Message Discrimination

At the BS only messages with a correct Destination Point Code (DPC) are accepted. Other messages are discarded. It is recommended that discarding a message because of an incorrectly set point code should cause an incident report to be generated.

At an MSC (which has the capability of acting as an STP), administration procedures may determine that each message received from a BS signaling link is passed through a "screening" function that checks that the DPC of the message is the same as the Signaling Point (SP) code of the exchange. If that is the case, the message is sent to the normal MTP message handling functions. Otherwise, the message is discarded and an incident report is made.

T1.111.4 Section 3 Signaling Network Management

Since the MSC-BS Interface utilizes point to point signaling between the BS and the MSC, the Signaling Route Management procedures, including the status of signaling routes, signaling route restricted, signaling route unavailability and availability, are not required.

1
2
3
4
5
6
7
8
9
10
11
12
13
14
15
16
17
18
19
20
21
22
23
24
25
26
27
28
29
30
31
32

T1.111.4 Section 3.8 Signaling Network Congestion

The procedures defined for U. S. Networks shall be followed for handling congestion on signaling links.

T1.111.4 Section 4 Signaling Traffic Management

Since the MSC-BS Interface utilizes point to point signaling, the Traffic Management procedures supporting signaling routes, including signaling route restricted, signaling route unavailability and availability, are not required.

T1.111.4 Section 4.2

The normal routing situation is that there are one or more signaling links available between the BS and MSC, and these links constitute a link set. They are run in load sharing mode and changeover and change back procedures are supported between these signaling links.

T1.111.4 Section 4.3.3

There is no alternative link set.

T1.111.4 Section 5 Changeover

Changeover between link sets is not applicable.

T1.111.4 Section 6 Change back

Change back between link sets is not applicable.

T1.111.4 Section 7 Forced Rerouting

Forced rerouting is not applicable since there is only one signaling route existing between the BS and the MSC.

T1.111.4 Section 8 Controlled Rerouting

Controlled rerouting is not applicable since there is only one signaling route existing between the BS and the MSC.

T1.111.4 Section 9 MTP Restart

The MTP Restart procedure is not required.

T1.111.4 Section 11 Signaling Traffic Flow Control

The Signaling Route Management procedures supporting signaling traffic flow control including signaling route unavailability and signaling route set congestion are not applicable for the MSC-BS Interface.

T1.111.4 Section 12 Signaling Link Management

Only basic link management procedures are applicable.

1 **T1.111.4 Section 13 Signaling Link Management**

2 Signaling Route Management procedure is not applicable for the MSC-BS Interface since
3 it is a point to point connection. No action is required upon reception of a Transfer-
4 Prohibited Signal (TFP), Transfer-Restricted Signal (TFR), Transfer-Allowed Signal
5 (TFA), Signaling Route Set Test, Signaling Route Set Congestion Test, or Transfer
6 Control message.

7 **T1.111.4 Section 14.2.1**

8 Since all messages are passed using the SCCP, the service indicator is: D=0, C=0, B=1,
9 A=1.

10 **T1.111.4 Section 14.2.2**

11 The sub service field is always set to D=1, C=0, to indicate a national network.

12 **T1.111.4 Section 15**

13 The formats and codes listed are only relevant to the messages that are required.

14 **4.2.5 Testing and Maintenance (T1.111.7)**

15 **T1.111.7 Section 2.1 Signaling Data Link Test**

16 The Signaling Data Link Test procedure is not required for the MSC-BS Interface.

17 **T1.111.7 Section 2.2**

18 The generation of a Signaling Link Test Message (SLTM) is not applicable at the BS,
19 however the BS shall be capable of responding with an acknowledgment message to a
20 SLTM.

21 **4.2.6 Interface Functions**

22 The method of interfacing to the higher layers is by the primitives defined in T1.111.1
23 [19].

24 The primitives defined are:

- 25 • MTP Pause indication
- 26 • MTP Resume indication
- 27 • MTP Status indication
- 28 • MTP Transfer request
- 29 • MTP Transfer indication

30 **4.2.7 Overload Control (Message Throughput Congestion)**

31 MTP overload control is not required.

4.3 SCCP Transport Layer Specification (SCCP Functions)

4.3.1 Overview

The purpose of this section is to identify the subset of the SCCP functions that are necessary to achieve the management of the MS transactions in the MSC-BS interface, and to provide addressing facilities. If this subset of SCCP functions is implemented, compatibility with a full ANSI SCCP shall be maintained. Only the needs of the BSAP are taken into account in this section.

The following simplifications are applicable to the signaling between BS and MSC in PLMNs:

- In order to limit the complexity of the procedures, a BS exchanges signaling messages only with its MSC, where a protocol conversion may be needed in some cases. Therefore, no SCCP translation function is required in the MSC between the national and the local SCCP and MTP within the MSC area.
- Several functions of the SCCP are not used on the MSC-BS interface: error detection, receipt confirmation, and flow control.
- The segmenting/reassembling function shall be used if the total message length exceeds the maximum allowed message length that can be carried by the MTP.
- T1.112.1 through T1.112.4 are considered as the basis for elaboration of this document.

4.3.2 Primitives (T1.112.1)

T1.112.1 Table 1

Two primitives of the table are not used:

N-INFORM DATA

N-RESET

T1.112.1 Table 2

The following parameters of the N-CONNECT primitive are not used:

Responding address

Receipt confirmation selection

Expedited data selection

T1.112.1 Table 3

The following parameter of the N-DATA primitive is not used:

Confirmation request

T1.112.1 Table 6

The following parameter of the N-DISCONNECT primitive is not used:

Responding address

1 **T1.112.1 Section 2.1.2**

2 Permanent signaling connections are not applicable.

3 **T1.112.1 Table 8**

4 The primitive N-NOTICE is not used.

5 **T1.112.1 Table 8A**

6 The following parameter of the N-UNITDATA primitive is not used:

7 Return option

8 **T1.112.1 Section 4.1.2**

9 Functions for permanent signaling connections are not applicable.

10 **4.3.3 SCCP Messages (T1.112.2)**

11 **T1.112.2 Section 2.4**

12 The Data Acknowledgment (AK) message is not used.

13 **T1.112.2 Section 2.6**

14 The Data Form 2 (DT2) message is not used.

15 **T1.112.2 Section 2.7**

16 The Expedited Data (ED) message is not used.

17 **T1.112.2 Section 2.8**

18 The Expedited Data Acknowledgment (EA) message is not used.

19 **T1.112.2 Section 2.10**

20 The Protocol Data Unit Error (ERR) message is not used; the inconsistent messages of
21 the SCCP protocol are discarded.

22 **T1.112.2 Section 2.13**

23 The Reset Confirm (RSC) message is not used.

24 **T1.112.2 Section 2.14**

25 The Reset Request (RSR) message is not used.

26 **T1.112.2 Section 3.5**

27 The Subsystem-Out-Of-Service-Grant (SOG) message is not used.

1 **T1.112.2 Section 3.4**

2 The Subsystem-Out-Of-Service (SOR) message is not used.

3 **T1.112.2 Section 2.16**

4 The Unit Data Service (UDTS) message is not used.

5 **T1.112.2 Section 4.2**

6 The “credit” parameter field is not used for protocol class 2. However, the parameter
7 shall still be included in the Inactivity Test (IT) message for syntax reasons.

8 **T1.112.2 Section 4.6**

9 The “error cause” parameter field is not used.

10 **T1.112.2 Section 4.10**

11 The “receive sequence number” parameter is not used.

12 **T1.112.2 Section 4.13**

13 The “reset cause” parameter field shall not be used.

14 **T1.112.2 Section 4.16**

15 The “sequencing/segmenting” parameter field is not used for protocol class 2. However,
16 the parameter shall still be included in the IT message for syntax reasons.

17 **4.3.4 SCCP Formats and Codes (T1.112.3)**

18 **T1.112.3 Section 3.4**

19 For point-to-point network structures (i.e., direct connections between the MSC and BS),
20 the called party address may consist of the single element: subsystem number.

21 No global title is used. The signaling point code which is coded in the MTP routing label
22 and the Subsystem Number (SSN) in the called party address allow the routing of the
23 message.

24 **T1.112.3 Section 3.4.2.2**

25 SSN Values: BSAP = 11111100, (252)

26 Use of alternative values is an administrative concern.

27 Note: It was determined that the IOS open A-Interface should use its own SSN value and
28 this was selected as BSAP = 11111100 (252).

29 **T1.112.3 Section 3.4.2.3**

30 Global title: refer to T1.112.3 [20] Section 3.4

1 **T1.112.3 Section 3.6**

2 Protocol Class: the classes 1 and 3 are not used.

3 **T1.112.3 Sections 3.8, 3.9, 3.10, 3.13, 3.14**

4 Parameters are not used.

5 **T1.112.3 Sections 4.8, 4.9, 4.11, 4.12, 4.13, 4.14, 4.15, 4.16**

6 Messages are not used.

7 **T1.112.3 Section 5.1.1**

8 SOR and SOG are not needed.

9 **4.3.5 SCCP Procedures (T1.112.4)**

10 **T1.112.4 Sections 1.1.2.2, 1.1.2.4**

11 Protocol classes 1 and 3 are not used.

12 **T1.112.4 Section 1.1.3**

13 A signaling connection consists of a single connection section. No intermediate nodes are
14 defined in the MSC-BS Interface.

15 The use of multiple connections sections is an administrative concern.

16 **T1.112.4 Section 1.2.1 (b)**

17 Not applicable for single connections.

18 **T1.112.4 Section 2.1 (1.)**

19 Global title not used for single connections.

20 **T1.112.4 Section 2.2.1**

21 Subsystem Number (SSN) is only present in the called party address for single
22 connections.

23 **T1.112.4 Section 2.2.2**

24 The addressing information may take the following form in the N-CONNECT request
25 primitive: DPC+SSN (for single connections).

26 **T1.112.4 Section 2.2.2.2**

27 No SCCP translation function is required for single connections.

28 **T1.112.4 Section 2.3.1 (3)**

29 Not applicable for single connections.

1
2
3
4
5
6
7
8
9
10
11
12
13
14
15
16
17
18
19
20
21
22

T1.112.4 Section 2.3.2 (4)

Not applicable for single connections.

T1.112.4 Section 3.1.3

Not applicable: no protocol class and flow control negotiations.

T1.112.4 Section 3.1.5

Not applicable.

T1.112.4 Section 3.2.2

Not applicable.

T1.112.4 Section 3.3.4

Not applicable.

T1.112.4 Section 3.5.1.2

Not applicable.

T1.112.4 Section 3.5.2

Not applicable.

T1.112.4 Sections 3.6, 3.7, 3.9, 3.10

Not applicable.

T1.112.4 Section 4.2

Message return is not applicable.

T1.112.4 Section 5

Only those messages and procedures relating to non-replicated subsystems or nodes are required. At the BS the concerned point is the parent MSC. The subsystem involved is the BSAP.

4.4 Use of the SCCP

24
25
26
27
28
29
30

The MTP and the SCCP are used to support signaling messages between the MSC and the BS. One user function of the SCCP, called Base Station Application Part (BSAP) is defined. The BSAP uses one signaling connection for the transfer of layer 3 messages per active Mobile Station (MS) having one or more active transactions (refer to section 4.4.3). The BSAP user function is further subdivided into two separate functions called DTAP (Direct Transfer Application Part) and BSMAP (BS Management Application Part).

Both connectionless (Class 0) and connection-oriented (Class 2) procedures are used to support the BSMAP. The procedure in this specification identify whether connection or connectionless services are to be used for each layer 3 procedure.

A distribution function located in the BSAP, which is reflected in the protocol specification by the layer 3 header, performs the discrimination between the data related to those two subparts. Refer to [14] for more information.

This section describes the use of an SCCP connection for an MS transaction. Section 4.4.1 identifies the Direct Transfer Application Part. Section 4.4.2 identifies the BS Management Application Part. Section 4.4.3 describes the connection establishment procedures. Section 4.4.4 describes the connection release procedures. [14] describes the distribution between BSMAP and DTAP messages and the data transfer over an SCCP connection.

4.4.1 The Direct Transfer Application Part

The Direct Transfer Application Part (DTAP) is used to transfer call control and mobility management messages to and from the MS. This layer 3 MSC-BS protocol in support of the MS-MSC call control and mobile management information exchange is referred to within this standard. The messages that transfer these information elements are also defined within this standard. Those messages that are considered DTAP are distinguished from BSMAP messages and are listed in [14].

4.4.2 The BS Management Application Part

The BS Management Application Part (BSMAP) supports other procedures between the MSC and the BS related to the MS, or to a cell within the BS, or to the whole BS. The description of the layer 3 protocol for the BSMAP information exchange is contained within this standard.

4.4.3 Connection Establishment

The initial messages exchanged in call setup are used to establish an SCCP connection for subsequent signaling communications relating to the call. A new connection is established when individual information related to an MS transaction is required to be exchanged between a BS and an MSC, and no such transaction exists between the MSC and that BS.

Two connection establishment cases are distinguished:

Case 1. A new transaction (e.g., Location updating, incoming or outgoing call – refer to [13]) is initiated on the radio path. Following an Access Request made by the MS on the Access Channel, the connection establishment is then initiated by the BS.

Case 2. The MSC decides to perform an inter-BS Handoff (refer to [13]). The connection establishment is then initiated by the MSC.

4.4.3.1 Establishment Procedure - Case 1

In this case, the connection establishment is initiated at the reception by the BS of the first layer 3 message from the MS. Generally, such a message contains the Mobile Identity parameter (ESN, or IMSI). The BS then constructs the first MSC-BS Interface BSMAP message (Complete Layer 3 Information) which includes one of the appropriate

1 DTAP messages (Location Updating Request, CM Service Request, or Paging Response)
 2 depending on whether the mobile station is accessing the network for the purpose of
 3 registration, call origination, or termination. The Complete Layer 3 Information message
 4 is sent to the MSC in the user data field of the SCCP Connection Request message (refer
 5 to [14]). The Complete Layer 3 Information message includes the cell identity and the
 6 layer 3 message that was received from the mobile. The exact coding of the BSMAP
 7 message is specified in [14].

8 At the reception of the SCCP Connection Request message, the MSC may check, based
 9 on the received identity, whether another association already exists for the same MS. If it
 10 is the case, the connection establishment is refused. Otherwise, an SCCP Connection
 11 Confirm message is sent back to the BS. This message may optionally contain a BSMAP
 12 or DTAP message in the user data field.

13 The diagram in Figure 4.4.3-1 shows a successful SCCP connection establishment
 14 procedure.

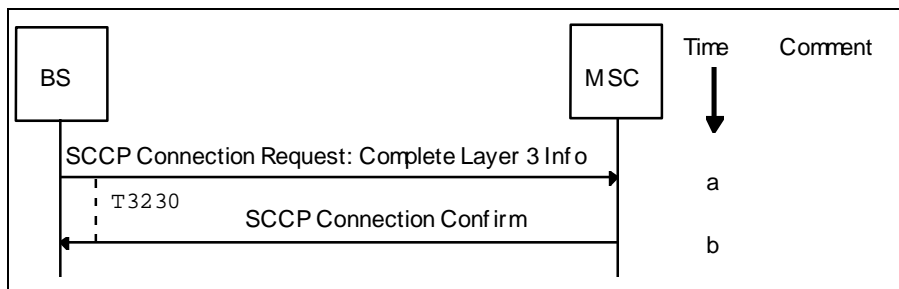

Figure 4.4.3-1 SCCP Connection Establishment

- 17 a. The BS sends an SCCP Connection Request message, including a user data
- 18 field, to the MSC. The BS starts timer T₃₂₃₀. Refer to [14] for the T₃₂₃₀ timer
- 19 definitions.
- 20 b. Upon receipt of the SCCP Connection Request message, the MSC sends an
- 21 SCCP Connection Confirm message, which may contain a Layer 3 application
- 22 message, to the BS. Upon receipt of this message, the BS stops timer T₃₂₃₀
- 23 and establishes the connection.

24 The procedures in case of connection establishment refusal are shown in Figure 4.4.3-2.

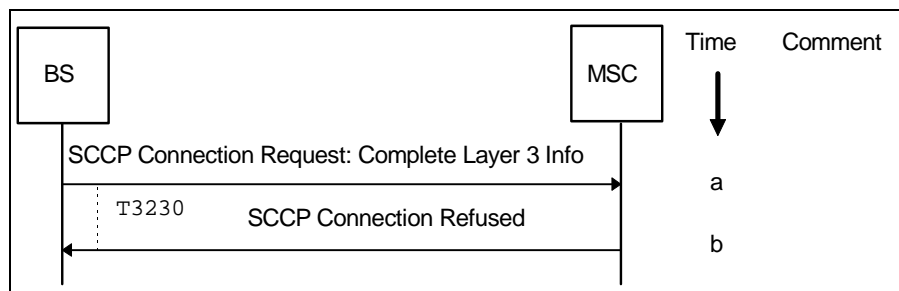

Figure 4.4.3-2 SCCP Connection Establishment Refusal

- 27 a. The BS sends an SCCP Connection Request message, including a user data
- 28 field, to the MSC. The BS then starts timer T₃₂₃₀.
- 29 b. Upon receipt of the SCCP Connection Request message, the MSC sends an
- 30 SCCP Connection Refused message to the BS. Upon receipt of this message,
- 31 the BS stops timer T₃₂₃₀.

1 If the user data field of the SCCP Connection Request message contains a Complete
 2 Layer 3 Info message with a Location Updating Request application message, the MSC
 3 shall respond with an SCCP Connection Refused message with a Location Updating
 4 Accept or Location Updating Reject message in the user data field.

5 4.4.3.2 Establishment Procedure - Case 2

6 In this case, the connection establishment is initiated by the MSC as soon as the MSC
 7 decides to perform an inter-BS Handoff.

8 An SCCP Connection Request message is sent to the BS. The user data field of this
 9 message shall contain the BSMAP Handoff Request message (refer to [14]). The layer 3
 10 messages shall be transferred in the user data field of the SCCP Connection Request in
 11 order to complete the establishment of the relation between the radio channel requested
 12 and the SCCP connection as soon as possible. The exact structure of the user data field is
 13 explained in [14].

14 When receiving the SCCP Connection Request message, the BS performs the necessary
 15 checking and reserves, in the successful case, a radio channel for the requested handoff.
 16 An SCCP Connection Confirm message is also returned to the MSC and shall contain the
 17 BSMAP Handoff Request Acknowledge message in the user data field.

18 The diagram in Figure 4.4.3.2-1 shows a successful SCCP connection establishment
 19 procedure during handoff.

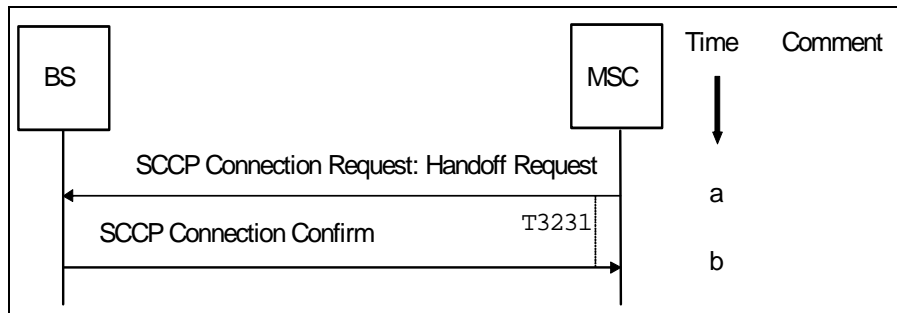

20
 21 **Figure 4.4.3.2-1 SCCP Connection Establishment During Handoff**

- 22 a. The MSC sends an SCCP Connection Request message, including a user data
 23 field that contains a Handoff Request application message, to the BS. The
 24 MSC starts timer T_{3231} ¹.
- 25 b. Upon receipt of the SCCP Connection Request message, the BS sends an
 26 SCCP Connection Confirm message, which shall contain the Layer 3
 27 application message Handoff Request Acknowledge, to the MSC and
 28 establishes the connection. Upon receipt of this message, the MSC stops timer
 29 T_{3231} .

30 The diagram in Figure 4.4.3.2-2 shows an SCCP connection refusal during handoff.

¹ Refer to [14].

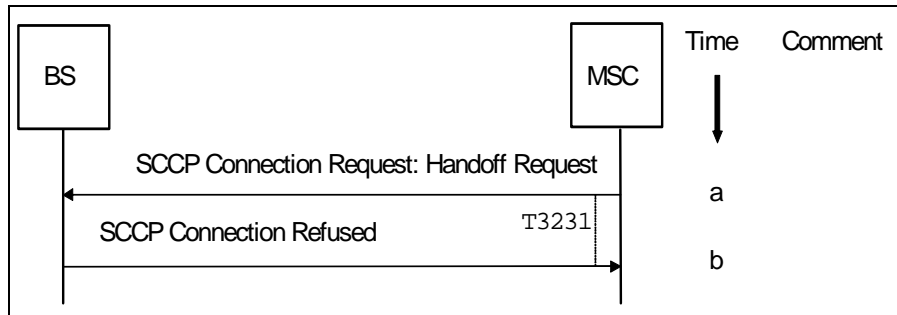

Figure 4.4.3.2-2 SCCP Connection Refusal During Handoff

- a. The MSC sends an SCCP Connection Request message, including a user data field that contains a Handoff Request application message, to the BS. The MSC starts timer T_{3231} .
- b. Upon receipt of the SCCP Connection Request message, the BS sends an SCCP Connection Refused message, which contains the Layer 3 application message Handoff Failure, to the MSC. Upon receipt of this message, the MSC stops timer T_{3231} .

4.4.4 Connection Release

This procedure is normally initiated at the MSC side but in the case of abnormal SCCP connection release (refer to 4.4.5), the BS may initiate connection clearing.

The MSC initiates this procedure with respect to the source BS in normal conditions for all calls supported by A1 connections.

A connection is released when a given signaling connection is no longer required. This may occur in normal cases:

- at the end of a transaction (call, location updating);
- after completion of a successful external Handoff: the connection with the old BS is released.

When either the MSC or the BS sends an SCCP Released (RLSD) message, the user data field is optional and may contain a transparent layer 3 message (e.g., DTAP) or be empty. The structure of the user data field, if any, is explained in [14].

When receiving this message, the BS releases or the MSC initiates release of all the radio resources allocated to the relevant MS, if there are still any left, and returns an SCCP Release Complete (RLC) message.

For abnormal cases a connection failure may be detected by the connection supervision service provided by SCCP. If so, the Reset Circuit procedure described in [14] is used. For other abnormal SCCP connection releases, refer to section 4.4.5 "Abnormal SCCP Release".

4.4.5 Abnormal SCCP Release

The normal release of SCCP A1 connections is initiated by the MSC. Under abnormal conditions, an SCCP connection may be released by the BS in order to clear resources.

Whenever an SCCP connection is abnormally released, all resources associated with that connection shall be cleared. Abnormal release can result from, for example, resource failure, protocol error, or unexpected receipt of the SCCP RLSD or SCCP RLC command.

4.4.5.1 SCCP Release by BS: Loss of SCCP Connection Information

Figure 4.4.5.1-1 demonstrates release of an SCCP connection by the BS due to loss of SCCP connection information. Note that when a circuit(s) is associated with the call at the MSC, Reset Circuit/Reset Circuit Ack [14] messages need to be exchanged between the MSC and BS to guarantee release of the circuit by both the MSC and BS.

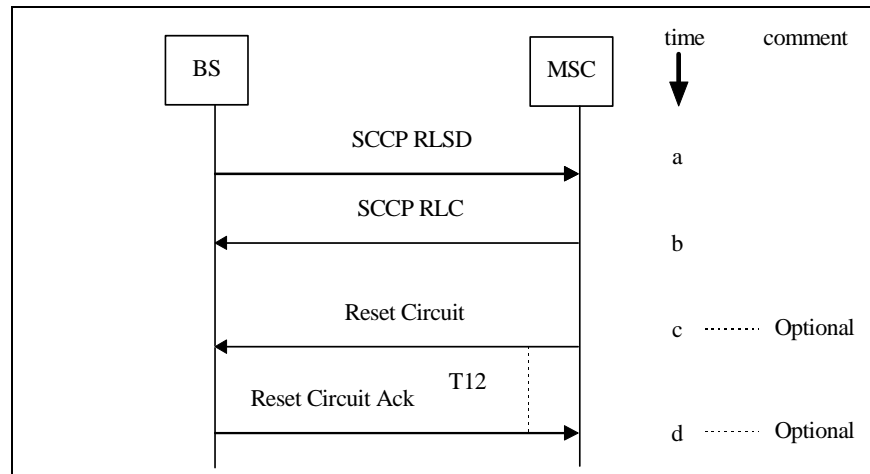

Figure 4.4.5.1-1 BS Generated SCCP Release: BS Has Lost Access to SCCP Connection Information

- a. An unexpected SCCP RLSD message (under abnormal termination) is received by the MSC from the BS.
- b. The MSC sends an SCCP RLC message to the BS to indicate that the SCCP RLSD message has been received and that the appropriate procedures have been completed.
- c. If a circuit was involved with the call at the MSC, the MSC sends a Reset Circuit message to inform the BS that had sent the SCCP RLSD to clear its call data and starts timer T_{12} ². The Reset Circuit message carries the Circuit Identity Code (CIC) of the trunk whose corrupted connection was released.
- d. The Reset Circuit Ack message informs the MSC that the Reset Circuit has been received and acted upon. The MSC stops timer T_{12} .

4.4.5.2 SCCP Release by MSC: Loss of SCCP Connection Information

Figure 4.4.5.2-1 demonstrates release of an SCCP connection by the MSC due to loss of SCCP connection information. Note that when a circuit(s) is associated with the call at the BS, Reset Circuit/Reset Circuit Ack messages [14] need to be exchanged between the MSC and BS to guarantee release of the circuit by both the MSC and BS.

² Refer to [14].

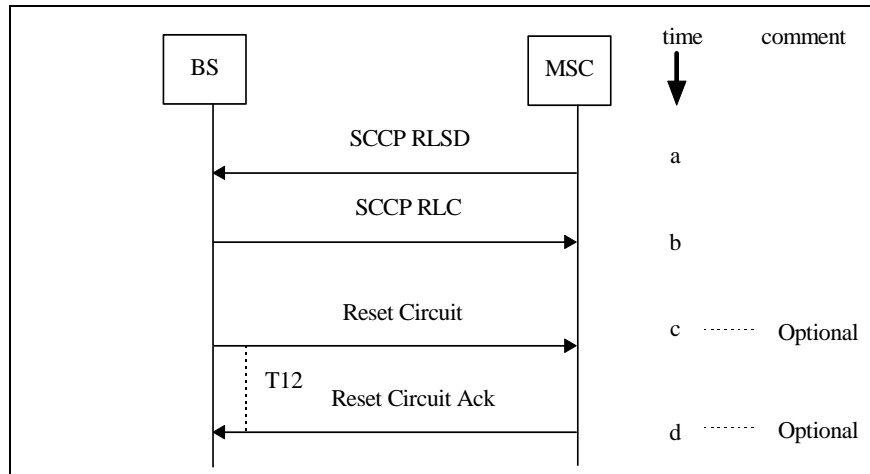

Figure 4.4.5.2-1 MSC Generated SCCP Release: MSC Has Lost Access to SCCP Connection Information

1
2
3
4
5
6
7
8
9
10
11
12
13
14

- a. An unexpected SCCP RLSD message (under abnormal termination) is received by the BS from the MSC.
- b. The BS sends an SCCP RLC message to the MSC to indicate that the SCCP RLSD message has been received and that the appropriate procedures have been completed.
- c. If a circuit was involved with the call at the BS, the BS sends a Reset Circuit message to inform the MSC which had sent the SCCP RLSD to clear its call data and starts timer T₁₂. The Reset Circuit message carries the CIC of the trunk whose corrupted connection was released.
- d. The Reset Circuit Ack message informs the BS that the Reset Circuit has been received and acted upon. The BS stops timer T₁₂.

4.4.6 SCCP Reference Generation Philosophy

15
16
17
18
19
20
21
22
23
24

Referring to Figure 4.4.6-1 “SLR/DLR Usage,” the SCCP local reference number (source/destination) is a three byte element internally chosen by the MSC or BS to uniquely identify a signaling connection. In the direction MSC to BS, the source local reference is chosen by the MSC and the destination local reference is chosen by the BS. In the direction BS to MSC, the source local reference is chosen by the BS and the destination local reference is chosen by the MSC. In the direction MSC to BS, the MSC always echoes the BS SLR in the DLR field. In the direction BS to MSC, the BS always echoes the MSC SLR in the DLR field. Note that it is the responsibility of the BS and MSC to insure that no two calls have identical SCCP local reference numbers.

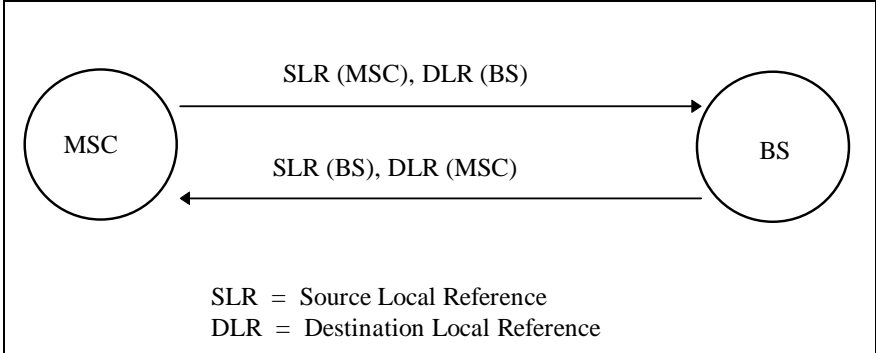

Figure 4.4.6-1 SLR/DLR Usage

MSC generation of SCCP local reference numbers shall conform to ANSI T1.112.4 [20], Section 3.1.2.

4.4.7 SCCP Transfer of DTAP and BSMAP Messages

The DTAP and BSMAP messages on the A1 interface are contained in the user data field of the exchanged SCCP frames. Table 4.4.7-1 below summarizes the use of the User Data Field in SCCP frames.

Table 4.4.7-1 Use of the User Data Field in SCCP Frames

SCCP Frame	User Data Field (BSMAP/DTAP)
Connection Oriented (CO) Protocol Class 2	
SCCP Connection Request (CR)	Optional
SCCP Connection Confirm (CC)	Optional
SCCP Connection Refused (CREF)	Optional
SCCP Released (RLSD)	Optional
SCCP Release Complete (RLC)	Not Applicable
SCCP Data Transfer 1 (DT1)	Mandatory
Connectionless (CL) Protocol Class 0	
SCCP Unit Data (UDT)	Mandatory

For connection oriented transactions, a connection is requested, obtained or refused using the following SCCP messages (protocol class 2):

- SCCP Connection Request (CR)
- SCCP Connection Confirm (CC)
- SCCP Connection Refused (CREF)
- SCCP Released (RLSD) and SCCP Release Complete (RLC) messages are used to break a connection.

The use of the User Data Field in SCCP frames in the various establishment and release cases is described in section 4.4.3 "Connection Establishment" and section 4.4.4 "Connection Release."

1 For connection oriented (protocol class 2) transactions, once the signaling connection is
 2 confirmed between the MSC and the BS, all A1 interface messages are transported in the
 3 SCCP Data Transfer 1 (DT1) message until the connection is to be dropped.

4 For Connectionless (protocol class 0) transactions, where there is no SCCP connection,
 5 A1 interface messages are transported in the SCCP Unit Data (UDT) message.

6 Table 4.4.7-2 below indicates which SCCP messages shall be used to transport each of
 7 the application messages on the A1 interface.

8 **Table 4.4.7-2 Use of SCCP for BSMAP and DTAP Messages**

Application Message	Message Discriminator	SCCP Message
Call Processing Messages		
Complete Layer 3 Information	BSMAP	CR ^a
CM Service Request	DTAP	CR ^{a,g}
Paging Request	BSMAP	UDT ^a
Paging Response	DTAP	CR ^{a,g}
Connect	DTAP	DT1
Progress	DTAP	DT1
Service Release	DTAP	DT1
Service Release Complete	DTAP	DT1
Assignment Request	BSMAP	CC ^b , DT1
Assignment Complete	BSMAP	DT1
Assignment Failure	BSMAP	DT1
Clear Request	BSMAP	DT1
Clear Command	BSMAP	DT1
Clear Complete	BSMAP	DT1
Alert With Information	DTAP	DT1
BS Service Request	BSMAP	UDT
BS Service Response	BSMAP	UDT
Additional Service Request	DTAP	DT1
Additional Service Notification	BSMAP	DT1

9

1

Table 4.4.7-2 (Cont.) Use of SCCP for BSMAP and DTAP Messages

Application Message	Message Discriminator	SCCP Message
Supplementary Services Messages		
Flash with Information	DTAP	DT1
Flash with Information Ack	DTAP	DT1
Feature Notification	BSMAP	UDT ^a
Feature Notification Ack	BSMAP	UDT ^a
PACA Command	BSMAP	CC ^b , DT1
PACA Command Ack	BSMAP	DT1
PACA Update	BSMAP	DT1
PACA Update Ack	BSMAP	DT1
Radio Measurements for Position Request	BSMAP	DT1
Radio Measurements for Position Response	BSMAP	DT1
Mobility Management Messages		
Authentication Request	DTAP/BSMAP	DT1/UDT ^c
Authentication Response	DTAP/BSMAP	DT1/UDT ^c
SSD Update Request	DTAP	DT1
Base Station Challenge	DTAP	DT1
Base Station Challenge Response	DTAP	DT1
Status Request	DTAP/BSMAP	DT1/UDT ^c
Status Response	DTAP/BSMAP	DT1/UDT ^c
SSD Update Response	DTAP	DT1
Location Updating Request	DTAP	CR ^{a,g}
Location Updating Accept	DTAP	CREF
Location Updating Reject	DTAP	CREF
Parameter Update Request	DTAP	DT1
Parameter Update Confirm	DTAP	DT1
Privacy Mode Command	BSMAP	DT1
Privacy Mode Complete	BSMAP	DT1
User Zone Reject	DTAP/BSMAP	DT1/UDT ^c
User Zone Update	DTAP	DT1
User Zone Update Request	DTAP	DT1

2

1

Table 4.4.7-2 (Cont.) Use of SCCP for BSMAP and DTAP Messages

Application Message	Message Discriminator	SCCP Message
Handoff Messages		
Handoff Required	BSMAP	DT1
Handoff Request	BSMAP	CR ^d
Handoff Request Acknowledge	BSMAP	CC ^d
Handoff Failure	BSMAP	DT1 ^f , CREF ^e
Handoff Command	BSMAP	DT1
Handoff Required Reject	BSMAP	DT1
Handoff Commenced	BSMAP	DT1
Handoff Complete	BSMAP	DT1
Handoff Performed	BSMAP	DT1
Facilities Management Messages		
Block	BSMAP	UDT
Block Acknowledge	BSMAP	UDT
Unblock	BSMAP	UDT
Unblock Acknowledge	BSMAP	UDT
Reset	BSMAP	UDT
Reset Acknowledge	BSMAP	UDT
Reset Circuit	BSMAP	UDT
Reset Circuit Acknowledge	BSMAP	UDT
Transcoder Control Request	BSMAP	DT1
Transcoder Control Acknowledge	BSMAP	DT1
Application Data Delivery Service (ADDS) Messages		
ADDS Page	BSMAP	UDT
ADDS Transfer	BSMAP	UDT
ADDS Deliver	DTAP	DT1
ADDS Page Ack	BSMAP	UDT
ADDS Deliver Ack	DTAP	DT1
ADDS Transfer Ack	BSMAP	UDT
Error Handling Messages		
Rejection	DTAP/BSMAP	DT1/UDT ^c

2

Following are the footnotes referred to in Table 4.4.7-2.

3

a. Required, SCCP DT1 is not an option.

4

b. May be used if responding to a CM Service Request or Paging Response.

5

c. Used only when the procedure is done on a paging channel.

6

d. Required only for hard handoffs.

7

e. May be used if responding to an SCCP Connection Request/Handoff Request.

- 1 f. May be used after an SCCP connection has been established.
- 2 g. Sent within Complete Layer 3 Information, which is a BSMAP message.
- 3

1
2
3
4
5
6
7

(This page intentionally left blank.)

5.0 Use of ATM (Layer 2)

When Asynchronous Transfer Mode (ATM) is used to provide signaling transport, the ATM Adaptation Layer 5 (AAL5) protocol is employed.

When ATM is used to provide user traffic (voice/data) transport, the AAL2 protocol is used. The procedures defined in [15] determine the allocation and use of the logical channels, i.e., the connection identifiers (CIDs) that AAL2 provides over an ATM virtual circuit.

Each BS has two or more ATM virtual circuits that connect it to other BSs (regardless of whether switched or permanent virtual circuits are used). These virtual circuits are comprised of one or more virtual circuits using the AAL5 protocol for signaling, and one or more virtual circuits using AAL2 for the user traffic connections.

Use of the AAL5 Permanent Virtual Circuit (PVC)/Switched Virtual Connection (SVC) as the link layer of IP protocol stack shall follow [29]. Specification of either Logical Link Control (LLC)/Sub Network Attachment Point (SNAP) encapsulation or Virtual Channel (VC) multiplexing as per [27] is left to the discretion of operators and manufacturers.

5.1 ATM Layer

The ATM Layer uses a basic 53 octet cell consisting of a 5 octet header and 48 octet payload. This standard uses the ATM Layer as specified in [21] without modification.

For this specification only ATM permanent virtual circuits (PVC's) shall be required for the A3 and A7 interfaces. These virtual circuits shall be configured through administrative procedures and no special signaling interface procedures, e.g., ATM UNI [23], shall be required.

5.2 ATM Adaptation Layer

To make use of the basic cell transfer capability of the ATM Transport Layer in specific usages, various ATM Adaptation Layers (AALs) have been defined.

Within this standard, two AALs are used:

- AAL5 - for the transfer of signaling, and
- AAL2 - for the transfer of user traffic (voice/data) on A3 traffic subchannels.

Both AAL5 and AAL2 are used without modification in this standard. The Service Specific Segmentation and Reassembly (SSSAR) sublayer for AAL2, as specified in [22], is used for segmentation and reassembly of AAL2 SDUs.

In this version of this standard, the functionality of other sublayers of AAL2 are not supported. Specifically, Service Specific Transmission Error Detection (SSTED) and Service Specific Assured Data Transfer (SSADT) are not included.

1 **5.3**

Use of ATM AAL5 for Transmission of IP Datagrams

2

Use of the AAL5 PVC/SVC as the link layer of IP protocol stack shall follow [29].
Specification of either LLC/SNAP encapsulation or Virtual Channel (VC) multiplexing
as per [27] is left to the discretion of operators and manufacturers.

3

4

5

6.0 TCP Transport Protocol Usage

The standard TCP protocol, as described in [26], shall be used for establishing, using, and clearing TCP connections.

6.1 General Use of TCP

TCP connections for signaling may be set up on a per-call basis or signaling messages for multiple calls may be multiplexed on a single TCP connection.

The TCP protocol provides a reliable byte stream transfer. Therefore, a means needs to be provided for two application entities to delimit the messages sent between them. The technique for such delimitation is given below.

6.1.1 Message Delimiting in TCP

TCP provides a reliable byte stream between two application entities. Because the protocol in this standard uses messages to communicate, these messages shall be delimited in the TCP byte stream. Such delimitation shall be done by means of a two byte flag field and a two byte length field inserted at the beginning of each message sent over a TCP connection. The flag field shall contain the hex value "F634". The purpose of the flag field is to facilitate verification of message boundaries, and fast reestablishment of synchronization if synchronization of message boundaries is lost. Refer to Figure 6.1.1-1.

	7	6	5	4	3	2	1	0
Flag	1	1	1	1	0	1	1	0
Flag	0	0	1	1	0	1	0	0
Length	(MSB) -----							
Length	----- (LSB)							
Msg	First Octet of IOS Application Message							
	Second Octet of IOS Application Message							
	Third Octet of IOS Application Message							
	...							
	Last Octet of IOS Application Message							
Flag	1	1	1	1	0	1	1	0
Flag	0	0	1	1	0	1	0	0
Length	(MSB) -----							
Length	----- (LSB)							
-- Continued on next page --								

Figure 6.1.1-1 Delimiting Messages in an IOS Application TCP Byte Stream

1

-- Continued from previous page --								
Msg	First Octet of IOS Application Message							
	Second Octet of IOS Application Message							
	Third Octet of IOS Application Message							
	...							
	Last Octet of IOS Application Message							
Flag	1	1	1	1	0	1	1	0
Flag	0	0	1	1	0	1	0	0
Length	(MSB)	-----						(LSB)
Length								
Msg	First Octet of IOS Application Message							
	Second Octet of IOS Application Message							
	Third Octet of IOS Application Message							
	...							

2

Figure 6.1.1-1 (Cont.) Delimiting Messages in an IOS Application TCP Byte Stream

3

6.1.2 TCP Connection Establishment

4
5
6

A new TCP connection is established when a signaling message is required to be exchanged over an interface, and no such connection exists over the particular interface. Normal active-passive TCP connection establishment procedures are used.

7

6.1.3 TCP Connection Release

8
9
10

An existing TCP connection over an interface may be released when there are no more signaling messages to be exchanged over the interface. Normal TCP connection release procedures are used.

11

6.1.4 TCP Port Usage

12
13
14
15
16

The following TCP port values are reserved for signaling across A interfaces:

- A7: (BS-to-BS) 5602 — This is the registered TCP port at a BS used for signaling interconnection to another BS.
- A9: (BS-to-PCF) 5603 — This is the registered TCP/UDP port at a BS used for signaling interconnection to a PCF.

17

6.2 Use of TCP for the A3 and A7 Interfaces

18
19

The standard "Transmission Control Protocol (TCP)", as described in [26] and shown in section 6.1 shall be used on the A3 (signaling subchannel) and A7 interfaces.

20
21

All response messages associated with the handoff procedures shall be sent back to the same TCP connection where the first A3 or A7 message initiating the procedure is

1
2
3
4
5
6
7
8
9
10
11

received. For example, A3-Connect Ack message is sent back to the same TCP connection from which A3-Connect message is received.

Any A3 or A7 signaling link disconnection during a handoff procedure may result in a failure of the handoff procedure. Optionally, a connection recovery may be performed for continuation of the handoff procedures. If a connection recovery is performed, the same active-passive TCP establishment procedure shall be used.

6.3 Use of TCP for the A9 Interface

When TCP is used for transferring the A9 interface messages, the standard "Transmission Control Protocol (TCP)", as described in [26] and shown in section 6.1, shall be used.

1
2
3
4
5
6
7

(This page intentionally left blank.)

1 **7.0 IP Network Protocol Usage**

2 The standard IP protocol, as defined in [25], shall be used for routing Internet Protocol
3 packets. When IP is used as the network layer for the A10 bearer, standard IP QoS
4 mechanisms may be employed.

5

6

1
2
3
4
5
6
7

(This page intentionally left blank.)

1 **8.0 UDP Transport Protocol Usage**

3 **8.1 UDP Transport Protocol Usage for the A11 Interface**

4 The use of UDP over the A11 interface conforms to the use of UDP for Mobile IP, as
5 specified in [28] with the exception of UDP port number as specified in section 9.0.

6 **8.2 UDP Transport Protocol Usage for the A9 Interface**

7 When UDP is used for transferring the A9 interface messages, the standard "User
8 Datagram Protocol (UDP)", as described in [24], shall be used.

9 The following UDP port value is reserved for signaling across A9 interface:

10 A9: (BS-to-PCF) 5603 — This is the registered UDP port at a BS used for signaling
11 interconnection to a PCF.

12 The initiator (BS) of an A9 link picks an available source UDP port, and sends an A9-
13 Setup-A8 message to the destination (PCF) at port 5603. The PCF responds with an A9-
14 Connect-A8 message to the UDP port of the BS that initiated the A9-Setup-A8 message.

15 The UDP protocol provides a transfer mechanism between the BS and the PCF with a
16 minimum of overhead.

1
2
3
4
5
6
7

(This page intentionally left blank.)

1 **9.0 Mobile IP Protocol Usage**

2 Mobile IP based messages are used for A11 interface call control signaling and for
3 passing accounting related and other information from the PCF to the PDSN. Each
4 signaling exchange consists of a request message and a reply message. When a message
5 is sent by the PCF, the PCF's A11 IP address shall be used as the IP Source Address and
6 the PDSN's A11 IP shall be used as the IP Destination Address. When a message is sent
7 by the PDSN, the PDSN's A11 IP address shall be uses as the IP Source Address and the
8 PCF's A11 IP address shall be used as the IP Destination Address. Each message is
9 transported within a UDP datagram. The initiator of the request message shall pick an
10 available UDP source port, and set the UDP destination port to 699 in the request
11 message it sends to the selected receiver. In the reply message it sends to the initiator, the
12 receiver shall pick an available UDP source port (it can use the UDP destination port in
13 the request message) and set the UDP destination port to the DUP source port in the
14 request message.

15

16

1
2
3
4
5
6
7

(This page intentionally left blank.)

1 **10.0 GRE Protocol Usage**

2 The upper layer for the A8 and A10 interfaces is the Generic Routing Encapsulation
 3 (GRE) protocol as defined in [30] .

4 The A10 bearer connection is used for the transport of user data for a packet data session.
 5 Link layer/network layer frames are carried between the PCF and the PDSN encapsulated
 6 in GRE packets, which in turn are carried over IP. The PCF-Address and the PDSN-
 7 Address are used in the source address and destination address fields of the IP header
 8 used with the GRE packet. In the bearer traffic direction from the PDSN to the PCF, the
 9 key field in the GRE header contains the PCF Session Identifier (PCF SID), and indicates
 10 which packet data bearer connection a particular payload packet belongs to. In the bearer
 11 traffic direction from the PCF to the PDSN, the key field in the GRE header contains the
 12 PDSN Session Identifier (PDSN SID).

13 When the PDSN SID is unique within the PDSN, the PDSN can use it to identify which
 14 bearer connection the packet belongs to. Otherwise, the PDSN may use the combination
 15 of the PCF Address and the PDSN SID parameters of each received packet in order to
 16 identify the associated packet data bearer connection.

17 With the A10 connection in place, link layer/network layer frames pass over this
 18 connection in both directions via Generic Routing Encapsulation (GRE) framing. The
 19 PDSN accepts these frames, strips the GRE, and processes them as normal incoming
 20 frames for the appropriate interface and protocol. The other direction behaves
 21 analogously, with the PDSN encapsulating the link layer/network layer frames in GRE,
 22 and the PCF stripping the GRE before passing the frames over to the upper layer. At this
 23 point, there is a point-to-point link layer/network layer connection between the MS and
 24 the PDSN.

25 GRE encapsulates user traffic as shown below.



26
 27 **Figure 10-1 GRE Encapsulated User Traffic**

28 Figure 10-2 shows the structure of the GRE header.

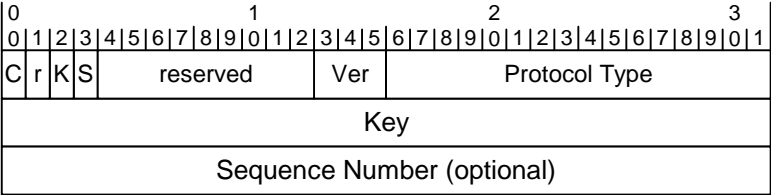

29
 30
 31 **Figure 10-2 GRE Header**

32 The GRE header shall be encoded as follows:

- 33 C (Checksum Present) '0'
- 34 r (reserved) '0'

1	K (Key Present)	'1'
2	S (Sequence Number Present)	'0 or 1'
3	reserved	'00000000'
4	Ver (Version Number)	'000'
5	Protocol Type	Hex '88 0B' for PPP (Note: currently '88
6		0B' is not supported by [8] , but is reserved
7		for pure PPP.)
8		Hex '88 81' for Unstructured Byte Stream

9 The BS shall set the Key field in the GRE header to the value in the Key field in the A8
10 Traffic ID element in the A9-Connect-A8 message received from the PCF indicating that
11 the PCF accepts the A8 connection. The PCF shall set the Key field in the GRE header to
12 the value in the Key field in the A8 Traffic ID element in the A9-Setup-A8 message
13 received from the BS requesting the establishment of the A8 connection.

14 The PCF shall set the Key field in the GRE header to value in the Key field in the Session
15 Specific Extension in the A11-Registration Reply message received from the PDSN
16 indicating that the PDSN accepts the A10 connection. The PDSN shall set the Key field
17 in the GRE header to the value in the Key field in the Session Specific Extension in the
18 A11-Registration Request message received from the PCF requesting the establishment
19 of the A10 connection.

20 If the link layer/network layer protocol requires that the GRE packets be delivered in
21 sequence over the connection, the S indicator shall be set to '1' and the sequence number
22 field shall be included in each GRE packet sent over the connection. When the sequence
23 number field is included, the sender and receiver shall perform the following:

- 24 • The Sequence Numbers shall be set to zero after the connection is established.
- 25 • The sequence number shall be incremented according to [31] in each
26 subsequent packet sent on the same connection
- 27 • Receipt of an out-of-sequence packet on a connection shall be handled
28 according to [31].

29

